

16E1 + 1 Ethernet Fiber Optical Multiplexer **User's Manual**

To users :

Thank you for using our products. Before using, please read this Reference Manual carefully, and keep properly.



Alarm

1. This product cannot be caught in or be affected with damp, for they can make the performance degressive and even broken.
2. Before fixing this product, please check the model and according to the User s' Reference Manual.

Contents

CHAPTER 1 GENERAL INTRODUCTION.....	3
1.1 PRODUCT DESCRIPTION.....	3
1.2 PRINCIPLE CHART AND DESCRIPTION.....	3
1.2.1 Description.....	4
1.3 CHARACTERS.....	4
CHAPTER 2 FUNCTIONS	5
2.1 FRONT PANEL.....	5
2.1.1 LED.....	5
2.1.2 Buttons in front panel.....	6
2.1.3 Hot line phone (optional port).....	6
2.1.4 Front panel DIP definition	7
2.2 REAR PANEL	9
2.2.1 Power Supply.....	9
2.2.2 Ethernet (optional component).....	9
2.2.3 Fiber interface.....	10
2.2.4 E1 interface (75Ω: BNC)	10
CHAPTER 3 PARAMETERS AND INDEX.....	11
3.1 PARAMETERS.....	11
3.1.1 Fiber interface.....	11
3.1.2 E1 interface.....	11
3.1.3 10/100Base-T Port.....	11
3.2 DIMENSION	11
3.3 POWER SUPPLY.....	11
3.4 OPERATION CONDITION	12
CHAPTER 4 OPERATION	13
4.1 EQUIPMENT INSTALLATION	13
4.2 QUICK INSTALLATION.....	13
4.3 CAUTIONS ABOUT INSTALLATION	14
CHAPTER 5 PACKAGE.....	15

CHAPTER 1. GENERAL INTRODUCTION

1.1 Product Description

16E1 + 1Ethernet Fiber Optical Multiplexer can multiplex to 16 E1 signals for transmission over an optical fiber, resulting in reaching a longer distance without a repeaters and superior performance compared to copper media.

16E1 + 1Ethernet Fiber Optical Multiplexer is the 16E1 point-to-point optical transport equipment that uses the FPGA chips and it is easy to upgrade. It is single board structure and the largest transmission capacity is 16E1. The outer design use the standard 19 inches rack, so the volume is little, weight is light and operation is convenient and credit.

16E1 + 1 Ethernet Fiber Optical Multiplexer uses the PDH fiber transmission technologies. The 2Mbps (E1) interfaces can connect with the exchanger, light loop device and multi-diplexer directly to the special network. Complete alarm function for 16E1 Fiber Optical Multiplexer, it is stable and easy to maintenance, install and small in size. It has one digital service telephone.

1.2 Principle Chart and Description

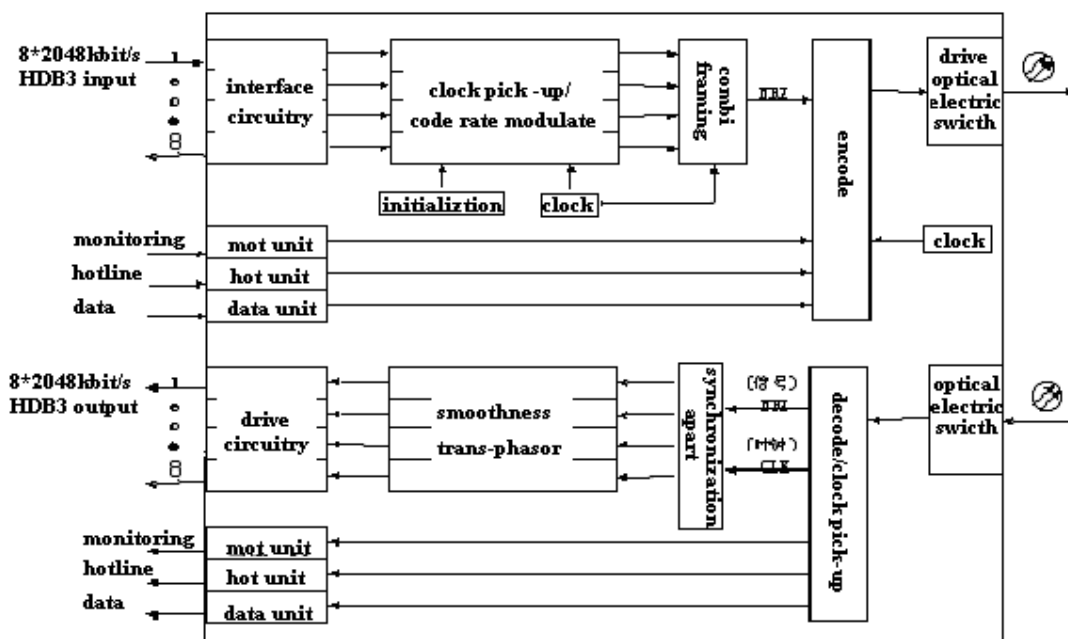

Fig1. PDH principle chart

1.2.1 Description

Device adopts veneer structure, and can be distinguished according to the functions into 5 parts: A. 2/8 combine unit, B. encode/decode unit, C. hot line unit, D. monitoring system, E. second power. A, B and E are the basic parts, achieving reverse conversion from 4 2048kbit/s signals to laser signal. C and D are of assistant.

1.3 Characters

- Base on IC of independence intellectual property rights
- Adopt veneer structure
- Offer 16 × 2Mb/s digital interfaces
- Up to 16E1 links on one fiber
- One link to service telephone for duty contract
- Provides 1 channel of 10M/100M, support VLAN setting.
- One channel OA for optional.
- When fiber signal is loss, users can distinguish whether the remote device is power off or the fiber line is down from the indicator status on the local device.
- 180-260VAC & -48VDC power options and the positive and negative of DC-48V can be optional because there is the self-test circuit for the polarity inside th1e device
- Standard 19 inches rack, little volume, light weight, steady capacity and convenient setup

CHAPTER 2. FUNCTIONS

2.1 Front Panel

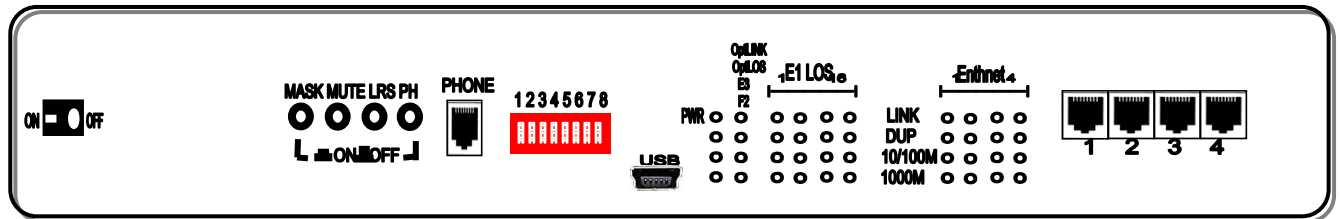

Fig2. Sketch map of the front panel

2.1.1 LED

No.	Name	Status	Describe
1	LOS1~16	Active	E1 loss
2	OPLOS	Active	Optical Signal lost
		Flick	2time/sec.: the remote device is power off
3	OPLOF	Active	Optical SYNC loss
4	E3	Active	Optical BER $\geq 10^{-3}$
5	F2	Active	Slave fiber line active, and the master down
6	PWR	Active	Power on
7	LINK/ACT	On/ Flick	LAN Linked/ transmission
8	DUP	On	Full duplex
9	10M/100M	On	Rate: 100M
10	1000M	\	\
others	Reserved for no use.		

Note: If the function is defined as 4E1/2E1, then LOS5-8/LOS3-8 is ineffective.

2.1.2 Buttons in front panel

PUSH	OFF	ON
MSK	DIP1-5 be used E1 warning shield	DIP1-5 be used E1 remote loop
MUTE	(standalone) warning voice is on	(standalone) warning voice is off
LRS	LED means Local	LED means Remote
PH	Hot line phone not used	Use Hot line phone

2.1.3 Hot line phone (optional port)

Hot line phone, not occupy 2Mbps channel transmission.

On the front panel there is a “PH” button, press on the “PH” button on the remote site it will sound.

To answer it the remote site just need to press the “PH” button on the remote unit, the alarm will cut off and just plug in the phone both side able to do the communication.

Setting of the manage phone.

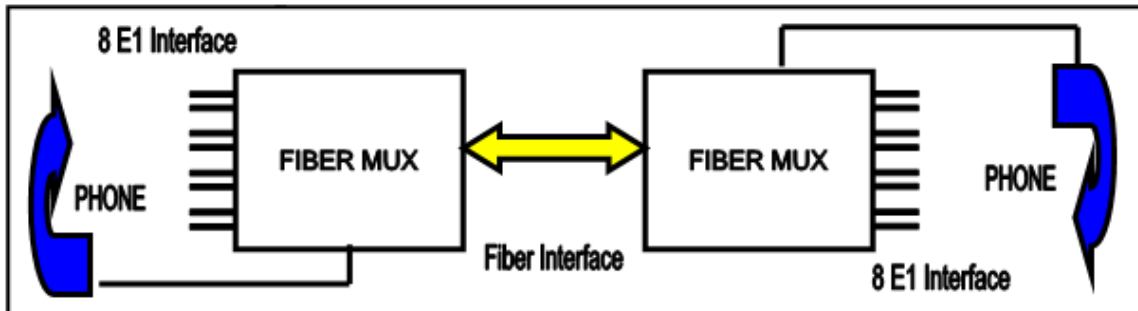

- It does not occupy the 2M circuits

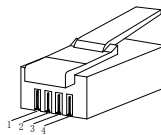

pin	definition	description
1	MIC-	MIC input -
2	SPEAKER+	Loudhailer output +
3	SPEAKER-	Loudhailer output -
4	MIC+	MIC input +

2.1.4 Front panel DIP definition

On the front panel of standalone / card in rack, the SW5 DIP definition shows as follows:

When MSK button pushes up, (RLOOP1-16): 1-16 E1 remote loop. If the RLOOP1 is ON, this means that at the far end it is doing a E1 loop-back

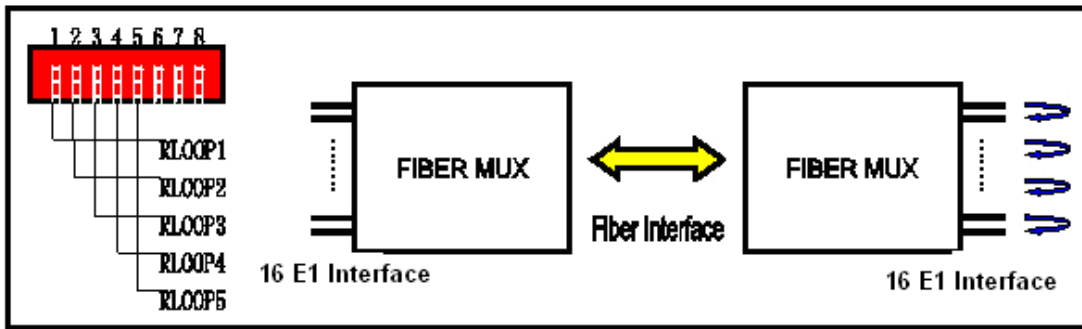

0 means ON, 1 means OFF

The corresponding E1 of remote Loop	MSK button	Bit1	Bit2	Bit3	Bit4	Bit5
1	push up	0	0	0	0	1
2	push up	0	0	0	1	0
3	push up	0	0	0	1	1
4	push up	0	0	1	0	0
5	push up	0	0	1	0	1
6	push up	0	0	1	1	0
7	push up	0	0	1	1	1
8	push up	0	1	0	0	0
9	push up	0	1	0	0	1
10	push up	0	1	0	1	0
11	push up	0	1	0	1	1
12	push up	0	1	1	0	0
13	push up	0	1	1	0	1
14	push up	0	1	1	1	0
15	push up	0	1	1	1	1
16	push up	1	0	0	0	0
All 16E1 Loop	push up	0	0	0	0	0
E1 not Loop	push up	other units				

Table 1

When MSK button push down, Bit1-5(mask1-5) mean 1-16E1 warning shielding.

1 means OFF, 0 means ON

Shielding E1 channel	MSK button contort	Bit1	Bit2	Bit3	Bit4	Bit5
16	push down	0	0	0	0	1
15-16	push down	0	0	0	1	0
14-16	push down	0	0	0	1	1
13-16	push down	0	0	1	0	0
12-16	push down	0	0	1	0	1
11-16	push down	0	0	1	1	0
10-16	push down	0	0	1	1	1
9-16	push down	0	1	0	0	0
8-16	push down	0	1	0	0	1
7-16	push down	0	1	0	1	0
6-16	push down	0	1	0	1	1
5-16	push down	0	1	1	0	0
4-16	push down	0	1	1	0	1
3-16	push down	0	1	1	1	0
2-16	push down	0	1	1	1	1
1-16	push down	1	0	0	0	0
E1 not shielding	push down	Other units				

Bit 6 : reserved.

Bit-7: ON: fiber interface local loop OFF: Cancel the loop

Bit-8: ON: The Ethernet interfaces are logically separated.

 OFF: The Ethernet interfaces are exchangeable.

2.2 Rear panel

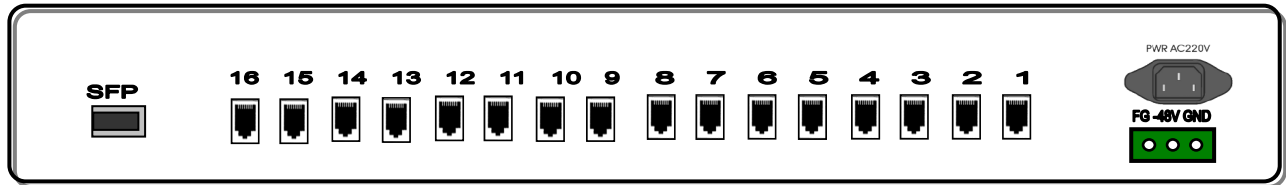

Sketch map of rear panel for 120Ω

2.2.1 Power Supply

Support AC220V and DC-48V

- AC220V: 180-260VAC, directly insert power wire;
- -48VDC: the positive and negative of DC-48V can be optional because there is the self-test circuit for the polarity inside the device

2.2.2 Ethernet (optional component)

This model can offer 1-4 channels for 10/100M, full/duplex auto-negotiation LAN interface, support VLAN protocol, this interface can continuous learn MAC addresses in the LAN that connected with it, and send the address as frame in another LAN. Transparency to TCP/IP protocol, offers security connection between different equipments in the network, used widely in network connection and monitor between WAN and LAN.

- 10/100 Base-T Ethernet port parameter
- Rate: 10M or 100M, full/semi duplex self adaption.
- Ethernet rate in optical line: 100Mbps.
- Protocol: support IEEE 802.3, IEEE 802.1Q(VLAN)
- MAC address table: can learn 4096 MAC address
- Ethernet buffer memory: 64 Mbits SDRAM
- Physical interface: RJ45 slot, support AUTO-MDIX

Ethernet operating diagrammatic:

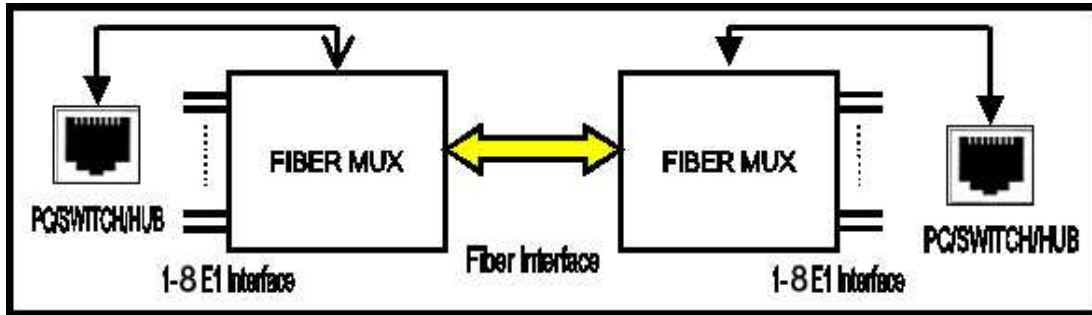

Ethernet RJ45 ports connection:

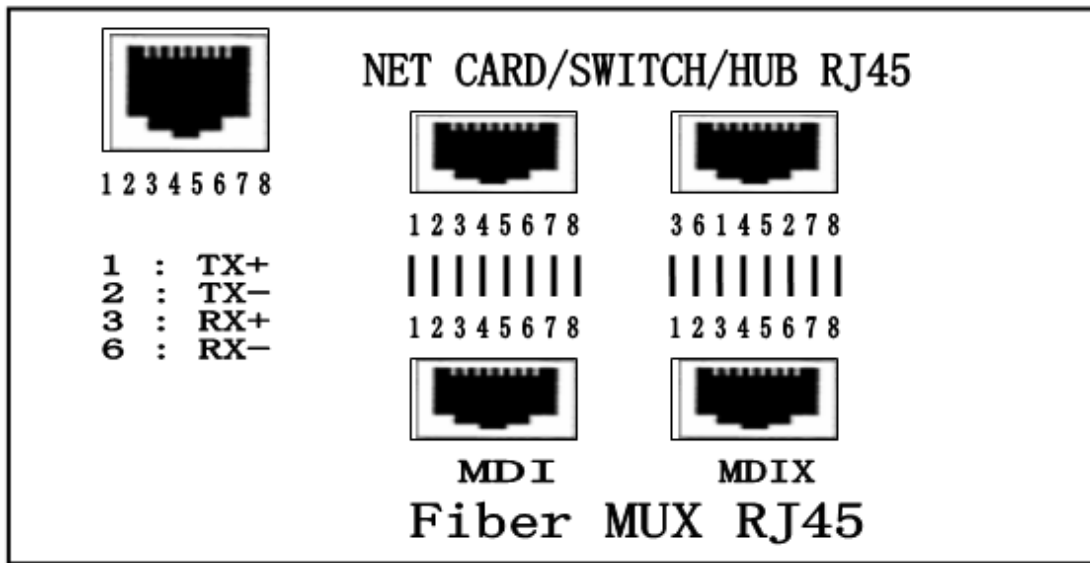

There are 2 light upon per RJ45.LNK on means that LAN Link and Active; SPD on means that ETH of 100M; SPD off means that ETH of 10M.

2.2.3 Fiber interface

There is SFP slot on the rear panel, supporting standard SFP module.

2.2.4 E1 interface

120Ω: 8 E1interface adopt RJ45, support 120Ω balance connection.

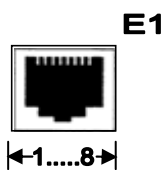

pin	definition	description
1	TX+	E1 output +
2	TX-	E1 output-
4	RX+	E1input +
5	RX-	E1 input-

CHAPTER 3. PARAMETERS AND INDEX

3.1 Parameters

3.1.1 Fiber interface

Optical interface: SFP lot (insert SFP module)

3.1.2 E1 interface

Interface code:	HDB3 code
Line speed:	2.048Mbps ±50ppm
Interface standard:	ITU-T G 703
Interface impedance:	75Ω/unbalanced (BNC) 120Ω/balanced (RJ45)
Allowed attenuation:	0~6dBm

3.1.3 10/100Base-T Port

Rate:	10/100M, full/duplex auto-negotiation
Protocol:	Support IEEE 802.3, IEEE 802.1Q (VLAN)
MACAddress Entries:	4096Entries
Connector:	RJ45

3.2 Dimension

485 mm (L) × 140 mm (W) × 44 mm (H)

3.3 Power supply

AC220V: input voltage AC 180V~260V

DC-48V: input voltage -36V~-72V

3.4 Operation Condition

Voltage:	AC180V ~ 260V; DC -48V; DC +24V
Consumption:	≤5W
Operating temperature:	0°C~50°C
Storing temperature:	-40°C~+70°C
Relative humidity:	95 %

Without disturbance of erosive and solvent gas, raising dust or strong magnetic field

CHAPTER 4. OPERATION

4.1 Equipment installation

After unpacking and before installation, make sure checking the following:

- Make sure the package is well. If the package is damaged, contact service office quickly for solution.
- Check the package according to the product list, if find equipment severe damaged or lack of some components, please contact installation worker or service office of us.
- Check whether the equipment type meets with the type you ordered.
- Check whether the component is in integrity.
- Check the power supply type.

4.2 Quick installation

- Fasten the Equipment in 19 inch rack with the screws in the equipment package.
- Use reliable ground connection at GND point of the equipment
- Use power tab to connect power according to the manual, don't exchange the polarities.
- Create user equipment connecting wire according to your demand (2M, V.35 and 10 Base-T), then connected, don't exchange receive and transfer wires.
- Connect SFP module to the SFP lot, make sure the optical fiber head is clean and connection well. (fiber bending radius \geq 50 mm)
- Use multimeter to test power polarity and voltage, make sure it matches with equipment requirement.
- After complete installation and make sure it's ok, power on the switch. Check indicator light meet with practice situation (see related part of manual).
- A clean, steady environment and firm installation should be provided for desktop or

wall hanging equipment.

4.3 Cautions about installation

- Avoid severe liberation and mechanical damage during the process of delivering and installation.
- Arrange fiber appropriately, fiber bending radius \geq 50 mm.
- Check voltage and polarity meet with back panel, or it will cause permanent damage to the equipment.
- The installation location should be convenient for personal passing and equipment movement.
- The environment should be dry, clean and ventilated well.
- Essential static-protective is needed during the installation and maintenance, ground the chassis to increase anti-interference capability and prevent lightning strike. Before use the equipment, independence work ground and protect ground should provided, make sure it ground well.

CHAPTER 5. PACKAGE

Contents in each box:

Fiber Optical Multiplexer	1
AC220V Power wire.....	1
User's manual.....	1

Note:

- Fiber Optical Multiplexer is a sensitive electronic item, please do handle with care when carrying or delivering and pay attention to against humidity.
- Within the warranty period, whenever there is a problem regarding the quality issue, we will take the responsibility for it and repair will done by us Free of Charge.
- After the warranty period, we will charge accordingly depending on the fault or damage.
- Whenever there is a malfunction of product, try to identify the problem according to alarm and contact our technical support in time.